

## Single or Dual MPC8640 VME SBC with up to 8 GbE Ports, Embedded L2 GbE switch and Virtex 5 FPGA

### Inside this issue:

#### Page 2

- Virtex-5 3U VPX board with FMC site
- 1U MicroTCA Chassis

#### Page 3

- XMC-ETH2: Robust dual Gigabit Ethernet mezzanine board
- RTI Eases Scaling and Integration of Real-Time Systems.

#### Page 4

- Software warranties — a new era?
- AdaCore Introduces Enhanced Version of GNAT Programming Studio

Interface Concept's **IC-De6-VMEb** is a VME64x board based on the Freescale e600 processor.

**IC-De6-VMEb** is powered either by one or two MPC8640 both available in Single or Dual core versions.

Designed for applications requiring a very high level of performance, the **IC-De6-VMEb** board also provides a very flexible combination of interfaces offering thus the ideal open platform for demanding customers.

Two Gig Ethernet ports provide the compatibility with VITA31.1 standard regarding packet switched architecture.

Its embedded Ethernet switch enlarges the communication capabilities usually existing on such a board, while the two PMC XMC slots allow the increase in the computing power or the range of available IOs.

An open FPGA completes the incredible flexibility of this board.

Environmental grades are available from air cooled through to rugged conduction cooled.

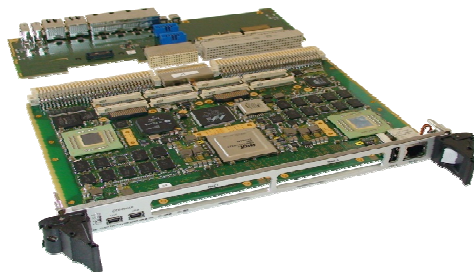

### Main Features:

#### Processor Unit

- 1 or 2 MPC8640 (D) running at 1GHz
- 2 or 4 DDRII banks with each up to 1 GB
- 1 or 2 128MB of soldered Mirror Flash
- 1 or 2 PPC 64-bit RTC and 32 bit-timers
- 1 or 2 Temperature sensors and monitoring
- 1 or 2 Calendar clock with supercap backup
- Elapse Time Counter
- DC and Thermal monitoring

#### Storage subsystem

- Up to 16GB of Soldered SSD Disk.

#### Communication subsystem

- up to 8 GigEthernet ports
- 1\*L2+ GbE switch (QoS, VLAN, etc.)
- 1\* RS232 and 1\* RS422 port per processor.
- USB2 external ports
- I2C bus

#### I/O subsystem

- VME64x with 2eSST (Tsi148)
- Two PMC/XMC slots :
  - PCI 32/64-bit at 33/66MHz, PCI-X up to 100 MHz
  - PCIe x4
- Slot 0 compatible with VITA35 P4V2-64ac, or Slot 0 & Slot 1 compatible with VITA35 P4V2-32+32ac
- One Open FPGA for customer applications (Virtex 5)

## Free Seminar: A Discussion of Multicore and Virtualisation in embedded systems

This will be a great opportunity to discuss, how the influx of multicore processors will impact your existing and future embedded designs. Participants will also learn about symmetric and asymmetric multiprocessing, virtualisation and partitioning techniques focused on multicore embedded devices.

**When:** 30th November 2009 , 9.30am—12pm

**Where:** Technology Park Conference Centre, Mawson Lakes.

**Register:** Tel. 08 8299 9333 or [info@dedicatedsystems.com.au](mailto:info@dedicatedsystems.com.au)

Find all details here: <http://www.dedicatedsystems.com.au/category/software-news/>

## Xilinx Virtex-5 3U VPX board with FMC site

**Interface Concepts IC-FEP-VPX3a** is powered by a Xilinx Virtex-5 SX95T (optionally FX70T or FX100T).

Designed for applications requiring a very high level of computing power in a compact 3U form factor, the **IC-FEP-VPX3a** board mixes the flexibility of a Virtex-5 FPGA and the VPX high bandwidth serial interfaces to provide the ideal platform for radar, sonar and other digital signal processing applications. A FMC mezzanine site enlarges the adaptability of the board to connect ADC, DAC, general IOs, FPDP and even additional FPGA FMC modules.

### Processor Unit : Xilinx Virtex-5

- Xilinx Virtex-5 XC5V SX95T FFG1136 package
  - 640 DSP48E slices
  - 14720 Virtex-5 Slices (4LUT+4 flip-flops per slice)
  - 488 BlockRAM (8784Kbits)
- Parallel Configuration flash : 16-bit wide, 128-Mbits
- One DDR2 controller : 32-bit wide, 256MBytes
- Two QDR2 controllers : each is 36-bit wide with up to 8MBytes

### VPX Interfaces

- three 4-lanes Fabric ports (on P1)
  - one PCIe x4 (port A)
  - two GTPx4 (ports B & C)
- two 1-lane ports (on P1)
  - a dual GTPx1 link usable as 2 1000BASE-KX ports
- General purpose IOs (on P2)
  - eight single-ended IOs
  - sixteen differential pairs
- One RS232 on P1 (Rx/Tx LVTTTL)

### FMC interfaces

- one GTPx4 link (limited to x2 when the dual GTPx1 link is used on P1 - user configuration)

- 68 differential pairs

### FX versions (Option)

- Xilinx Virtex-5 XC5VFX70T (resp.FX100T)
  - 296 (/456) DSP48E slices
  - 11200 (/16000) Virtex-5 Slices
  - 296 (/456) BlockRAM (8784Kbits)
  - one (/two) PPC 440 embedded core(s)
- SPI flash for PPC440 : 128-Mbits per PPC44

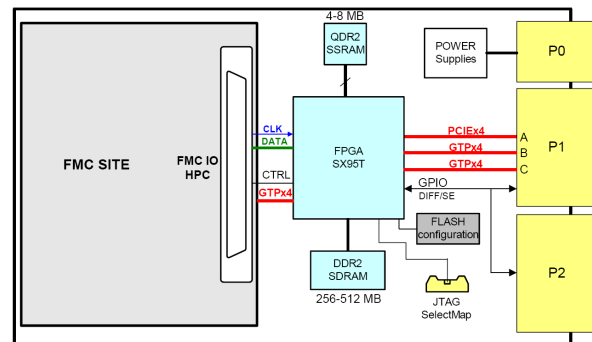

## Schroff's new 1U MicroTCA Chassis for 6 single size AMC Modules

### Features:

- 1 U MicroTCA system, for 6 single mid-size AdvancedMC modules and 1 full-size MCH
- AC mains input (85 ... 264 VAC) at rear of case, 250 W PSU fitted, power management on backplane
- Hot-swap fan module with 5 fans and cooling unit management
- Ventilation from right to left, cooling capacity: 30 W per AdvancedMC slot and 40 W for the MCH slot (at  $\Delta T = 12.5$  K)
- Air filter, swappable from front
- Up to 4 software protocols may be used simultaneously



## Kontron XMC-ETH2: Robust dual Gigabit Ethernet mezzanine board with long-term availability

With the new dual Gigabit Ethernet mezzanine board Kontron XMC-ETH2, all VPX, VME, CompactPCI and custom boards offering a PMC or XMC slot can be extended by two Gigabit Ethernet interfaces, which can be individually routed to the front or to the backplane. Equipped with the high-end Intel® 82571 Dual Channel Ethernet Controller, the Kontron XMC-ETH2 mezzanine board delivers best possible data throughput.

The new mezzanine board comes in two versions: air-cooled (Standard Commercial (SA)) or conduction-cooled (Rugged Conduction Cooled Version (RC)) in order to suit the individual needs of different system environments. Thanks to Kontron's dedicated long term supply (LTS) program, customers can enjoy 10+ years of guaranteed supply, making the Kontron XMC-ETH2 the ideal Ethernet mezzanine for infrastructure programs. Typical application areas can be found in markets such as medical, transportation, military, aerospace, energy and automation.

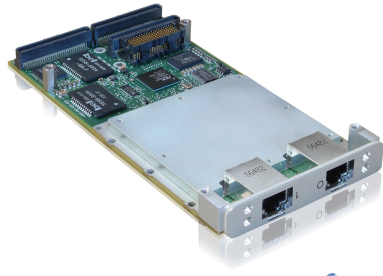

Kontron XMC-ETH2



Owing to the fact that the Kontron XMC-ETH2 mezzanine board supports both XMC and PMC extension slots, it can be used universally in different system designs. Designed as a Plug & Play solution, the Ethernet mezzanine board automatically selects the data bus according to whether the power supply is present on the P5 connector (x4 PCI Express). Otherwise, it switches to 32 bit PCI 33 MHz

or 66 MHz on the PMC connectors. An integrated micro DIP switch allows for manual override of the host bus selection. Another micro DIP switch controls Ethernet channel routing to the front panel (RJ-45) or to the backplane (P4). Each channel can be routed separately.

The Kontron XMC-ETH2 dual Gigabit Ethernet mezzanine board supports Linux, VxWorks and Windows XP and is available now: the SA version for air-cooled system designs in a temperature range of 0 °C to 55 °C (VITA 47-Class AC1) and the RC version for robust conduction-cooled systems in the extended temperature range of -40 °C to 85 °C (VITA 47-Class CC4).

## RTI Eases Scaling and Integration of Real-Time Systems Across WANs and Systems of Systems

Real-Time Innovations (RTI), The Real-Time Middleware Experts, announced the release of RTI Routing Service, which dramatically eases the scaling and integration of real-time systems across Wide Area Networks (WANs) and Systems of Systems. RTI Routing Service enables seamless communication between applications deployed in different locations or even applications supporting different external interfaces—without any changes to existing software. This dramatically reduces the time and cost required to integrate applications across geographically dispersed networks and Communities of Interest.

RTI Routing Service is based on the Object Management Group (OMG) Data Distribution Service for Real-Time Systems (DDS) standard. With DDS, applications communicate by exchanging messages and data. RTI Routing Service works by forwarding and transforming data as it flows between applications. As a result, applications do not have to accommodate differences in data types or natively support WAN communication. RTI Routing Service extends RTI's industry-leading DDS implementation, RTI Data Distribution Service, and also supports the DDS wire-interoperability protocol for compatibility with other compliant DDS implementations.

"Hundreds of systems rely on DDS and RTI Data Distribution Service for integration and information dissemination," commented Edwin de Jong, RTI's director of product management and strategy. "More and more of these systems are being integrated into WANs such as the Global Information Grid [GIG].

RTI Routing Service provides turnkey bridging capabilities. It also decouples individual systems by transforming and filtering data so disparate systems can seamlessly communicate."

RTI Routing Service can be deployed without any changes to existing applications. Thus, it can integrate existing systems without requiring source-code modifications. The service also isolates individual applications from WAN transport and security requirements. For example, local applications can communicate using IP multicast for efficient, broad data distribution while RTI Routing Service bridges sites using secure TCP connections for easy firewall traversal.

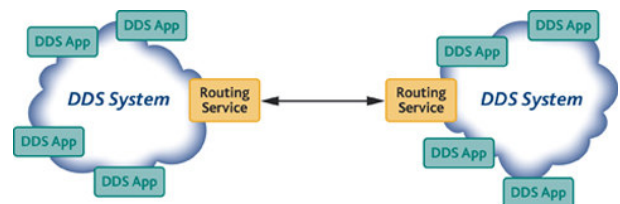

## Software warranties – A new era?

By Adacore CEO Dr. Robert Dewar

When anyone buys a television, a car, or even a ballpoint pen, the purchaser expects it to work properly. This assumption is backed by the legal machinery of warranties and consumer protection legislation. So software carries the same protection, right? Wrong! Historically, commercial software products have been sold with absolutely no claims that they are fit for purpose or free of vulnerabilities. But that might be changing, thanks to several factors.

Read the complete story here: <http://www.mil-embedded.com/articles/id/?4217>.

## AdaCore Introduces Enhanced Version of GNAT Programming Studio

AdaCore Introduces Enhanced Version of GNAT Programming Studio  
*GPS 4.4 Integrated Development Environment improves user interface, adds toolset support*

AdaCore, a leading supplier of Ada tools and support services, today announced the release of GNAT Programming Studio (GPS) 4.4. This new version of AdaCore's graphical Ada-oriented Integrated Development Environment (IDE) offers an improved user interface, faster performance and greater integration with AdaCore's Project Coverage and SPARK Pro toolsets. GPS is provided with GNAT Pro on most platforms, for both native and embedded software development. The most noticeable enhancement in GPS 4.4 is in the graphical user interface (GUI), which makes it easier for users to add new plug-ins and customize the IDE. The general navigation capabilities and documentation generation features have also been improved, ensuring consistent creation of supporting materials. And below the visible GUI, GPS now offers tighter integration with both the Project Coverage and SPARK Pro toolsets. Project Coverage's code coverage and simulator capabilities can now be directly accessed from the IDE, and support for the SPARK language has been extended, allowing improved source/annotation navigation. SPARK developers may now more easily develop SPARK language applications and invoke the SPARK Pro toolset from GPS.

Enhancements in GPS 4.4 include:

- Improved user interface look and feel
- Improved memory usage and speed
- New entity views
- Enhanced documentation generation to support both API documentation and source code browsing
- Hyperlinks added in source editor for quick source and web navigation
- Support for Project Coverage toolset invocation
- Improved SPARK Pro language and toolset support, in particular source navigation for annotations
- New "Tip of the Day" feature
- Support for filters in the locations display view
- Unified "visual diff" within the source editor
- Support for interleaved-Ada/Expanded-Ada (.dg files) in source editor
- Outline View updated in real-time, with the ability to display entities hierarchically
- New source navigation menus to display a type hierarchy
- New plug-ins, including:
  - Formatting preferences that can be automatically set from gnatpp project switches
  - Sources that can automatically be reformatted on save using gnatpp
  - Simplified new file creation

GPS 4.4 is compatible with GNAT Pro versions 3.16a1 up to 6.3. As with all GNAT Pro components, GPS is distributed with full source code and is backed by AdaCore's rapid and expert online support.